

· GH ·

CRANES & COMPONENTS

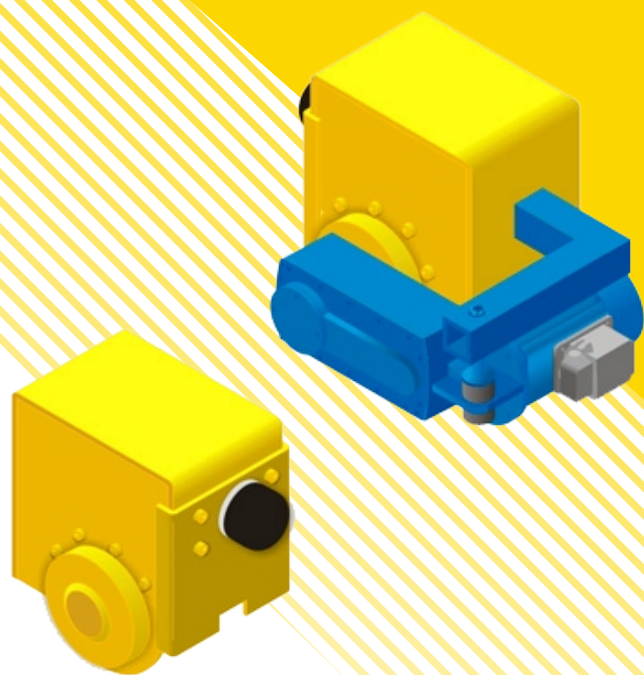

TESTEROS

—
COMPONENTES
PARA GRÚAS

TABLAS DE SELECCIÓN ORIENTATIVAS DE RUEDAS Y MOTORES

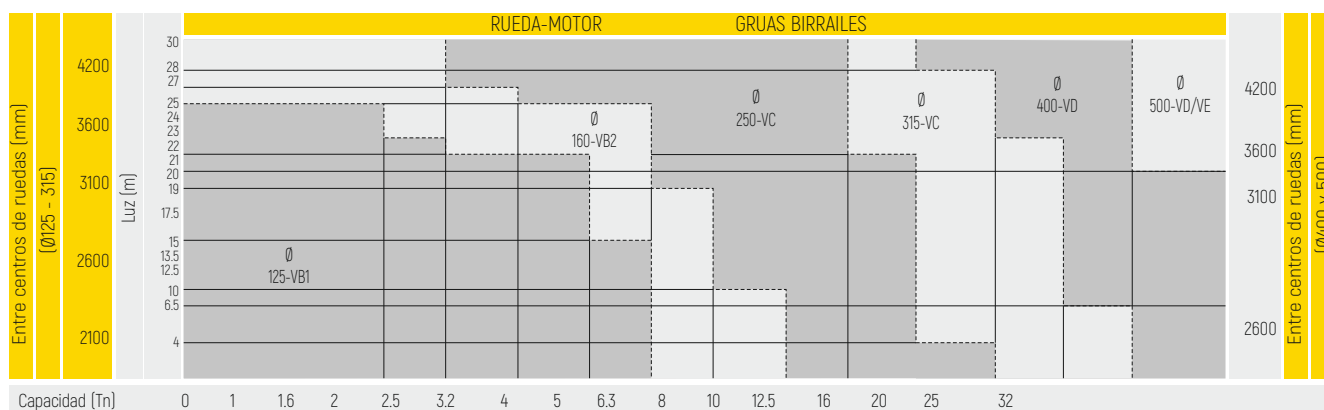
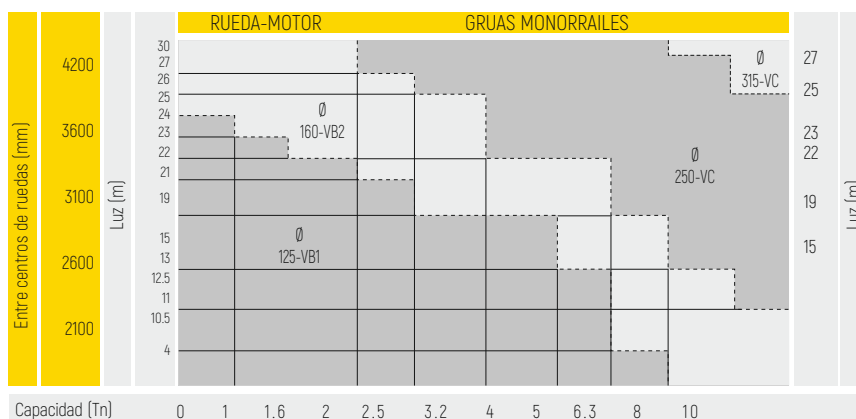

REFERENCIA DE LOS COMPONENTES DE TRASLACIÓN GH

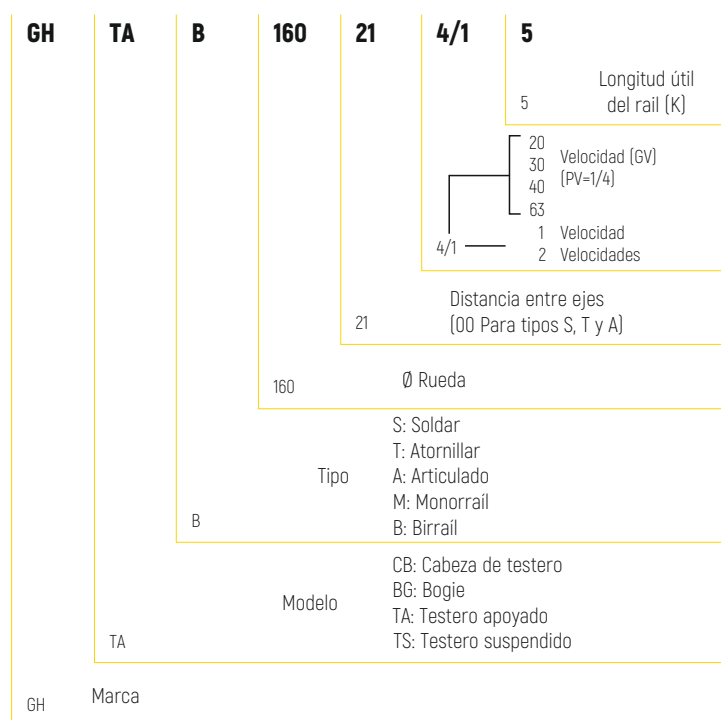

VELOCIDADES DE TRASLACIÓN A 3.000 rpm.

TESTEROS APOYADOS

Ø Rueda	Tipo Reduct.	Velocidades posibles en m/min						
		10	15	20	25	30	40	60
125	RFS/125	✗	✗	✗				
160	RFS/160							
250	RFS/250						3T	
315	RFS/315							
400	RFS/400							
500	RFS/500	✗		4T				
630	RFS/630	✗						

TESTEROS SUSPENDIDOS

Ø Rueda	Tipo Reduct.	Velocidades posibles en m/min					
		10	15	20	25	30	40
125	RFS/125						✗
160	RFS/160						✗
200	RFS/250			3T			✗
250							✗

MOTOREDUCTORES DE TRASLACIÓN

Los motoredutores de traslación están especialmente diseñados y fabricados por GH para el accionamiento de mecanismos destinados a la manutención de materiales.

La concepción especial de los motores GH garantiza los movimientos progresivos en la aceleración y en el frenado, así como un funcionamiento silencioso.

Las ruedas, sobre las que van instalados los rodamientos, son de doble pestaña, con motoredutores de ataque directo, por medio de eje estriado.

MOTOREDUCTORES DE TRASLACIÓN CON REDUCTORA DE TRES TRENES (3T) PARA VELOCIDADES STANDARD

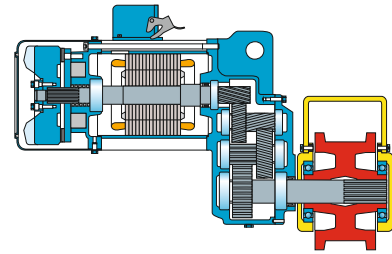
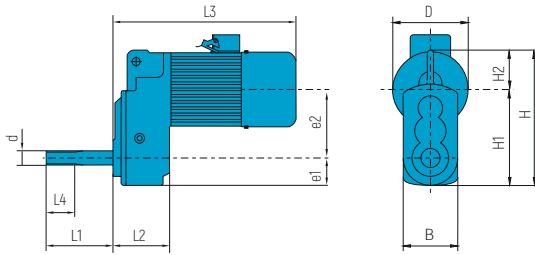

Peso Kg	Motor tipo	Reductora tipo	Pot. Motor (Kw) F=50 Hz		Ø d mm.	L1 mm.	L2 mm.	L3 mm.	L4 mm.	e1 mm.	e2 mm.	B mm.	Ø D mm.	H1 mm.	H2 mm.	H mm.
			3000 Var	3000/750												
24	VB1-60	RFS / 125-3T	0,85	0,40/0,10	34,9	152	112	389	60	60	134,2	120	157,5	194,2	78	273,2
32	VB2-60	RFS / 160-3T	0,85	0,75/0,18	34,9	166	134	448,5	70	67	168,25	134	157,5	235,25	90	325,25
34	VB2-100															
50	VC-85	RFS / 250-3T	1,5	1,5/0,37	49,9	240	146	492	60	90	218,05	180	218	308,05	109	417,05
54	VC-110															
50	VC-85	RFS / 315-3T	1,5	1,5/0,37	49,9	250	146	492	60	90	218,05	180	218	308,05	109	417,05
54	VC-110															
150	VD-110	RFS / 400-3T	5	3/0,75	64,9	316	235	592	65	130	323,7	250	265	453,7	135	588,7
150	VD-110	RFS / 500-3T	5	3/0,75	79,9	332	235	592	65	130	323,7	250	265	453,7	135	588,7
205	VE-110	RFS / 500-3T	7,5	5,1/1,3	79,9	332	235	672	65	130	323,7	250	327	453,7	135	617
320	VE-110	RFS / 630-3T	7,5	5,1/1,3	89,9	399	262	700	55	200	440,9	400	327	640,9	166	806,9

MOTOREDUCTORES DE TRASLACIÓN CON REDUCTORA DE CUATRO TRENES (4T) PARA PÓRTICOS Y VELOCIDADES ESPECIALES

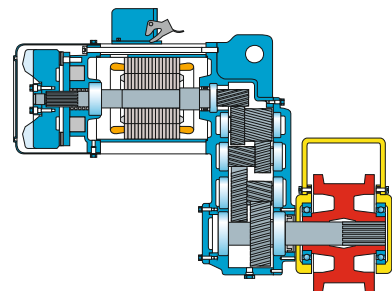
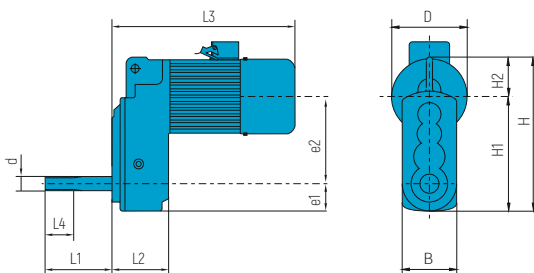

Peso Kg	Motor tipo	Reductora tipo	Pot. Motor (Kw) F=50 Hz		Ø d mm.	L1 mm.	L2 mm.	L3 mm.	L4 mm.	e1 mm.	e2 mm.	B mm.	Ø D mm.	H1 mm.	H2 mm.	H mm.
			3000 Var	3000/750												
36	VB2-60	RFS / 160-4T	0,85	0,75/0,18	34,9	166	154	463	70	75	240,8	150	157,5	315,8	90	405,8
38	VB2-100															
56	VC-85	RFS / 250-4T	1,5	1,5/0,37	49,9	240	160,5	495	60	100	289	200	218	389	109	498
60	VC-110															
56	VC-85	RFS / 315-4T	1,5	1,5/0,37	49,9	250	160,5	495	60	100	289	200	218	389	109	498
60	VC-110															
160	VD-110	RFS / 400-4T	5	3/0,75	64,9	316	235	592	65	145	447,7	290	265	592,7	135	727,7
160	VD-110	RFS / 500-4T	5	3/0,75	79,9	332	235	592	65	145	447,7	290	265	592,7	135	727,7
215	VE-110	RFS / 500-4T	7,5	5,1/1,3	79,9	332	235	672	65	145	447,7	290	327	592,7	135	756

TESTEROS PARA GRÚAS MONOVIGA Y BIRRAILES

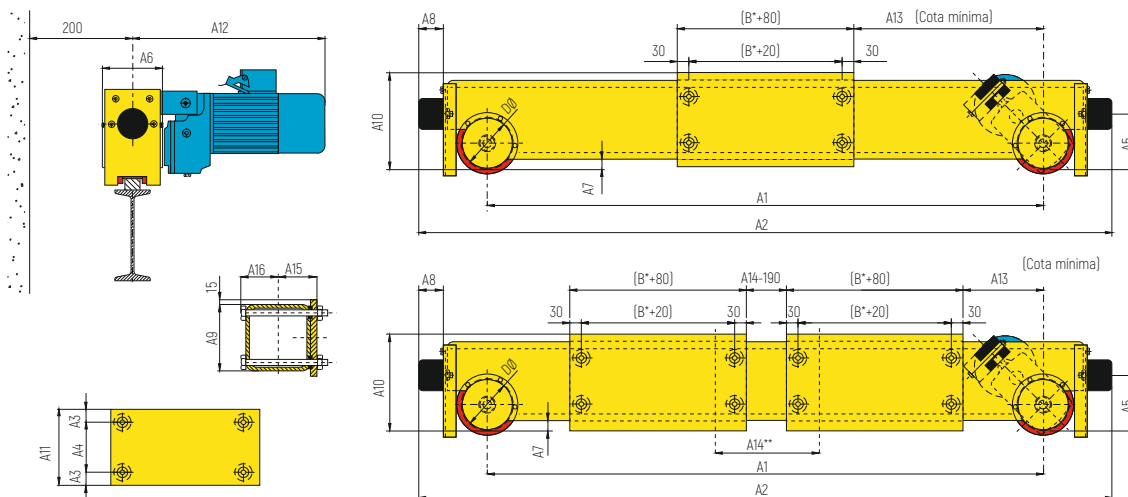

DØ	A1	A2	A3	A4	A5	A6	A7	A8	A9	A10	A11	A12	A13	A14	Monorrail A15	Birrail A15	A16	Monorrail Peso (Kg)	Birrail Peso (Kg)
100	1600	1932	50	130	118	152	13	58	200	228	230	469	185	330	80	80	---	96	113
	2100	2432			118									115				132	
	2600	2932			118									134				151	
	3100	3432			160									153				170	
	3600	3932			160									172				189	
125	1600	1960	50	130	125	171	20	80	200	235	230	475	185	900	97 [20]	97	103	135	--
	2100	2460			125									160				160	
	2600	2960			125									185				185	
	3100	3460			1200									210				210	
	3600	3960			1500									235				235	
160	1600	2035	50	180	160	175	37.5	97	250	302.5	280	536	900	107	97	103	175	--	
	2100	2535			160								205				205		
	2600	3035			1200								235				235		
	3100	3535			1200								265				265		
	3600	4035			1500								295				295		
	4200	4635			1800								330				330		

*La cota "B" corresponde a la medida de la platabanda de la viga

**La cota "A14" corresponde a la luz del carro

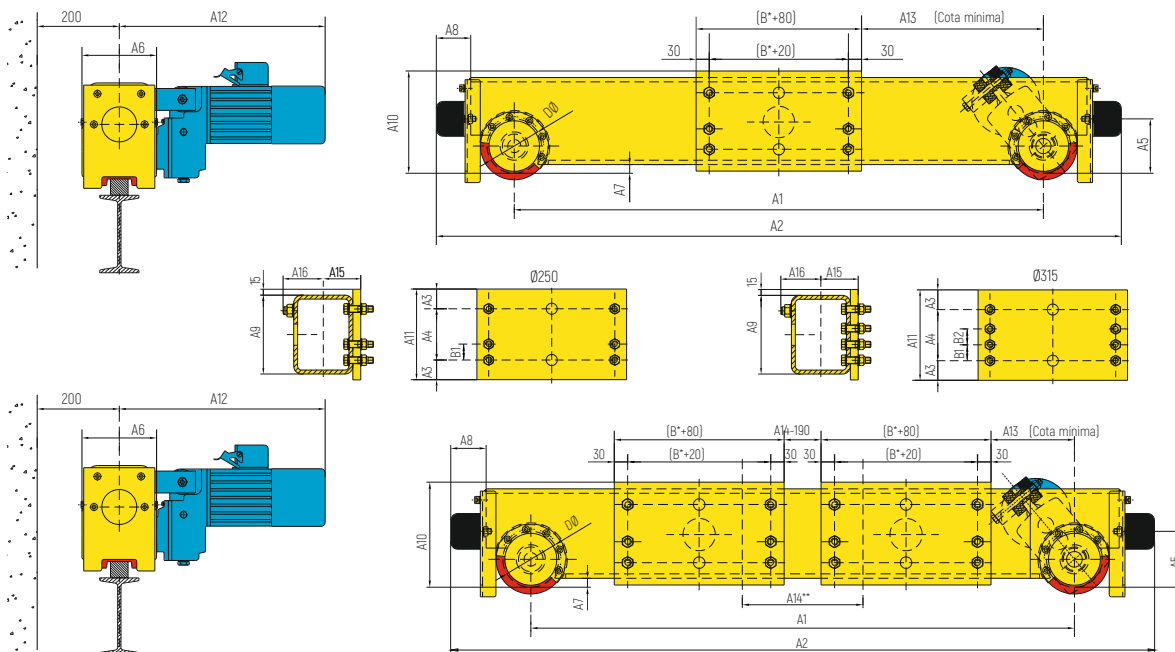

DØ	A1	A2	A3	A4	A5	A6	A7	A8	A9	A10	A11	A12	A13	A14	Monorrail A15	Birrail A15	A16	B1	B2	Monorrail Peso (Kg)	Birrail Peso (Kg)
250	2100	2665	65	200	250	258	30	117	300	345	330	621	295 (3T) 375 (4T)	900	120 [20]	120	128	60	--	335	335
	2600	3165												1200						380	380
	3100	3665												1200						425	425
	3600	4165												1500						470	470
	4200	4765												1800						525	525
315	2100	2725	70	290	315	268	62.5	117	400	477.5	430	626	205 (3T) 310 (4T)	130	120	128	65	65	505	505	
	2600	3225											1200						565	565	
	3100	3725											1200						625	625	
	3600	4225											1500						685	685	
	4200	4825											1800						760	760	

*La cota "B" corresponde a la medida de la platabanda de la viga

**La cota "A14" corresponde a la luz del carro

CARACTERÍSTICAS TÉCNICAS DE TESTEROS BIRRAILES

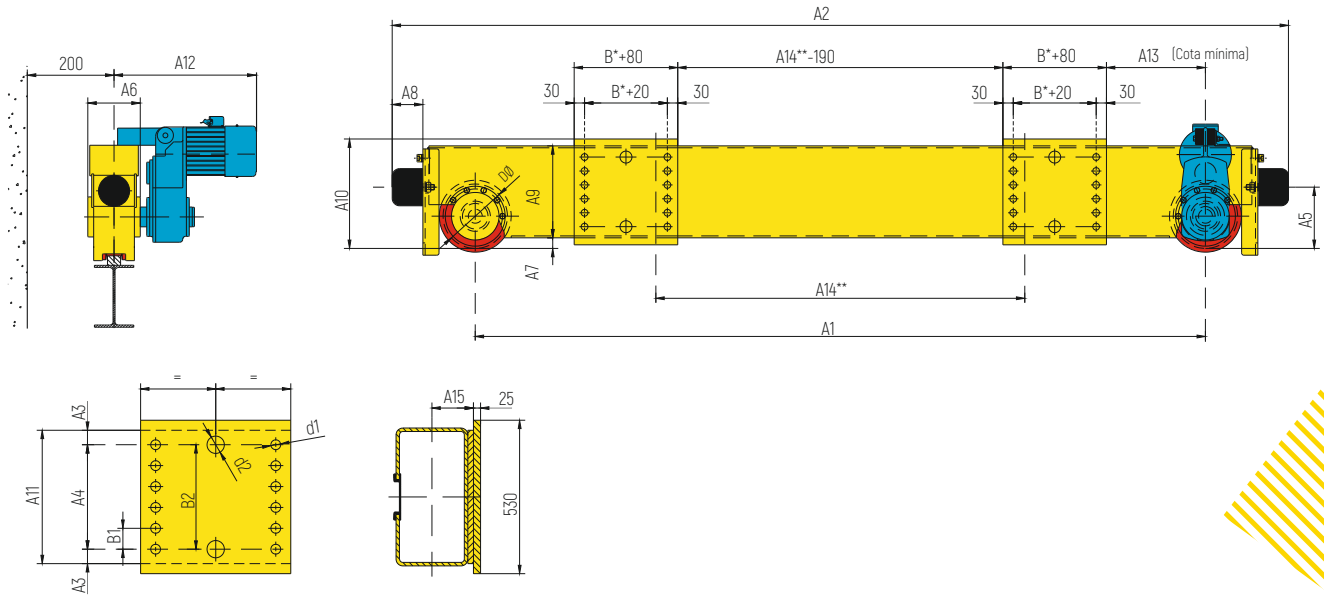

DØ	A1	A2	A3	A4	A5	A6	A7	A8	A9	A10	A11	A12	A13	A14	A15	B1	B2	Ød1	Ød2	Peso (Kg)
400	3100	3900	50	390	335	285	50	130	500	565	490	785	275	1500	120	78	390	24	40	930
	3600	4400												1500						990
	4200	5000												1800						1065
500	3100	4070	40	410	385	301	100	165	500	615	490	795	320	1500	120	82	380	26	70	1220
	3600	4570												1500						1290
	4200	5170												1800						1395

* La cota "B" corresponde a la medida de la platabanda de la viga

**La cota "A14" corresponde a la luz del carro

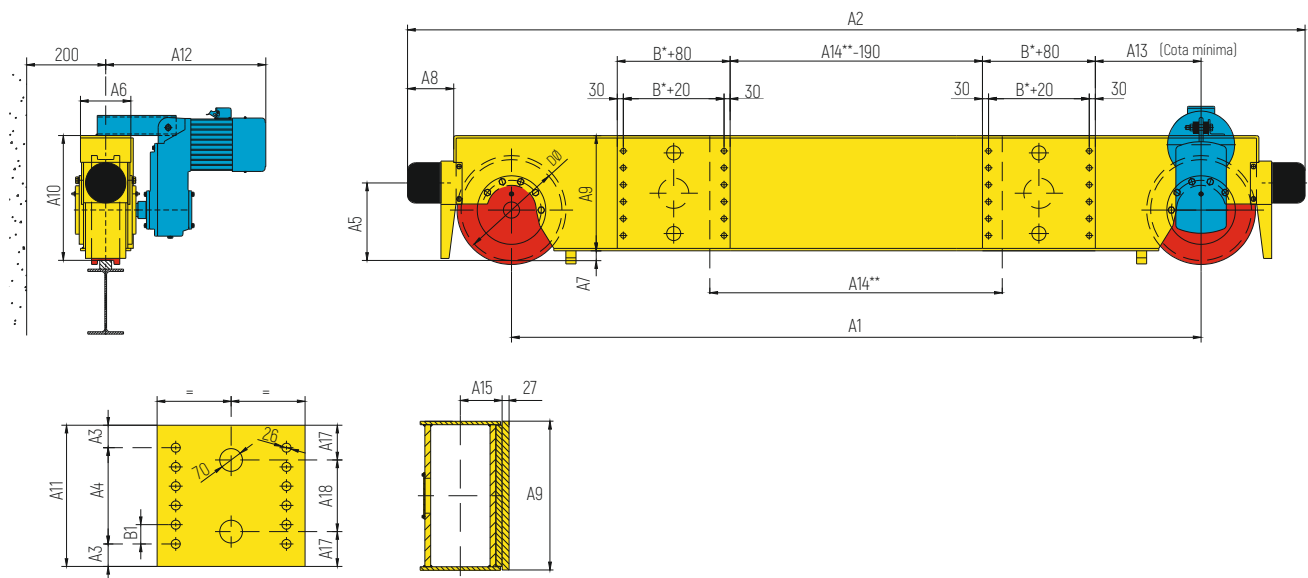

DØ	A1	A2	A3	A4	A5	A6	A7	A8	A9	A10	A11	A12	A13	A14	A15	A17	A18	B1	Peso (Kg)
500	3100	3900	66,5	410	385	301	48	230	571	619	543	795	320	1500	137	81,5	380	82	1490
	3600	4400												1500					1590
	4200	5000												1800					1700
630	3100	4070	33	540	495	383	45	268	640	685	606	930	390	1500	180	133	340	90	2435
	3600	4570												1500					2595
	4200	5170												1800					2790

La cota "B" corresponde a la medida de la platabanda de la viga

**La cota "A14" corresponde a la luz del carro

CARACTERÍSTICAS TÉCNICAS DE TESTEROS PARA GRÚAS SUSPENDIDAS

MONOVIGA SERIE MEDIANA MODELO TS - M

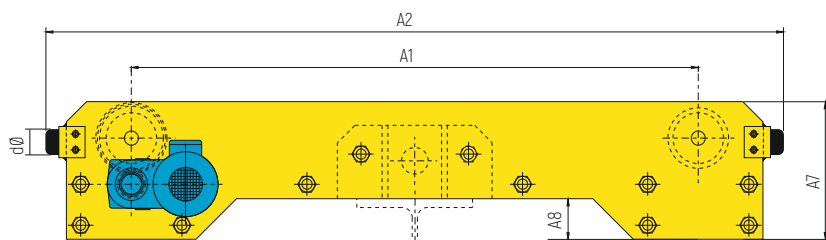

Luz m	A1 mm.	A2 mm.	A4 mm.	A5 mm.	A6 mínimo mm	A7 mm.	A8 mm.	IPN mínimo mm	Ø Rueda mm	Ød mm	Peso Kg	Carga media admisible por 2 ruedas (daN)
9 15	1200 2100	1600 2500	66	472	160	340	100	180	125	63	205 260	3600
9 15	1200 2100	1640 2540	71	522	198	390	105	220	160	63	275 360	5300
15 22	2100 3100	2630 3630	85	595	245	440	110	260	200	100	460 565	9300
15 22	2100 3100	2710 3710	95	595	287	540	130	320	250	100	730 885	13300

Nota: Las cotas A1 menores a 2100, serán sólo válidas para testereros sueltos

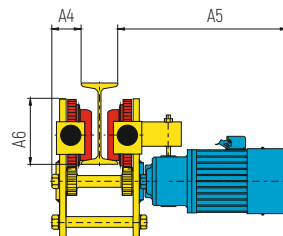

BIRRAIL SERIE MEDIANA MODELO TS - B

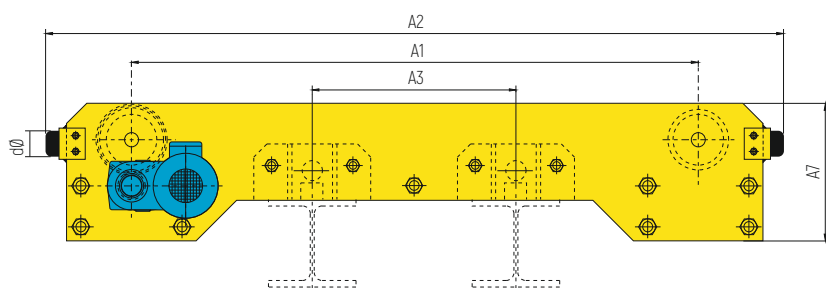

Luz m	A1 mm.	A2 mm.	A3 mm.	A4 mm.	A5 mm.	A6 mínimo mm	A7 mm.	A8 mm.	IPN mínimo mm	Ø Rueda mm	Ød mm	Peso Kg	Carga media admisible por 2 ruedas (daN)
9 15	1600 2100	2000 2500	900 900	66	472	160	340	100	180	125	63	230 260	3600
9 15	1600 2100	2040 2540	900 900	71	522	198	390	105	220	160	63	310 360	5300
15 22	2100 3100	2630 3630	900 1200	85	595	245	440	110	260	200	100	460 565	9300
15 22	2100 3100	2710 3710	900 1200	95	595	287	540	130	320	250	100	730 885	13300

Nota: Las cotas A1 menores a 2100, serán sólo válidas para testereros sueltos

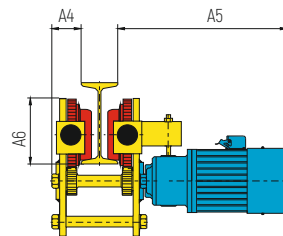

CABEZALES PARA TESTEROS DE GRÚAS PUENTE

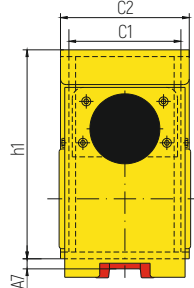
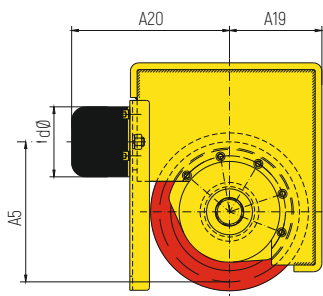

Cabezal para ruedas					
Ø125	Ø160	Ø250	Ø315	Ø400	Ø500

	Ø Rueda	Dimensiones							Ød
		C1	C2	H1	A5	A7	A19	A20	
Cabezal Solidado	125	150	180	205	125	10	100	179	80
	160	150	180	255	160	27.5	120	217	100
	250	200	230	373	250	18	165	282	125
	315	200	230	373	305	50.5	195	312	125
	400	225	250	506	335	38	262	400	160
	500	220	250	546	385	48	312	486	200
	630	305	345	645	495	45	373	645	250

Cabezal para rueda Ø 630	
--------------------------	--

CABEZALES PARA GRÚAS PÓRTICO

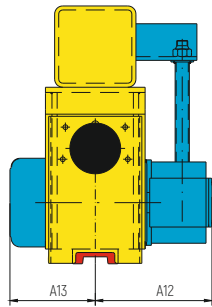
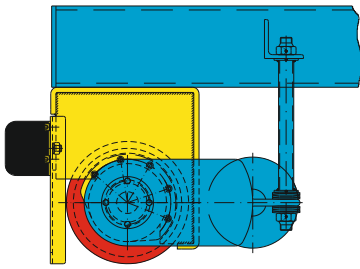

Ø Rueda	Tipo Reductora	Tipo Motor	Dimensiones	
			A12	A13
160	RFS/160-4T	VB2	234	222
250	RFS/250-4T	VC	282	215
315	RFS/315-4T	VC	287	210
400	RFS/400-4T	VD	420	172
500	RFS/500-4T	VD	428	165
630	RFS/630-3T	VE	928	192

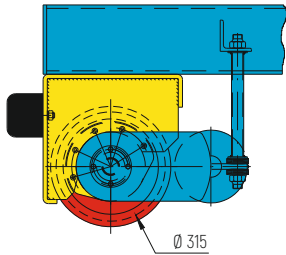

Carga máxima admisible por rueda en GG670 (daN)
S/Normas FEM/UNE Grupo M4

Ø Rueda	Velocidad de traslación en mm	Ancho carril de rodadura K (mm)				
		40	50	60	70	80
125	20	4500	5000			
	40	3600	4000			
	63	3200	3400			
160	20	5900	7000	8300		
	40	5000	6200	7400		
	63	4400	5400	6400		
250	20	9800	12200	14400		
	40	8900	11100	13400		
	63	8000	10000	12000		
315	20	12700	15800	18600	18600	
	40	11600	14500	17400	18600	
	63	10900	13500	16200	17600	
400	20	16500	20700	24800	28900	30000
	40	15200	18900	22700	26500	30000
	63	14200	17800	21400	24900	27800
500	20		26200	31500	36800	40000
	40		24400	29300	34200	39000
	63		23000	27600	32200	36800
630	20			40500	47200	52800
	40			38000	44300	50600
	63			35800	41800	47700

Cargas para relación Rmax/Rmin=0,35

Calidad mínima del rail de rodadura S355 [St52]

BOGIES PARA GRÚAS PÓRTICO

DIN	Tipo carril	Dimensiones	
		L	K
536	A 45	45	37
	A 55	55	45
	A 65	65	53
	A 75	75	59
	A 100	100	80
	A 120	120	100

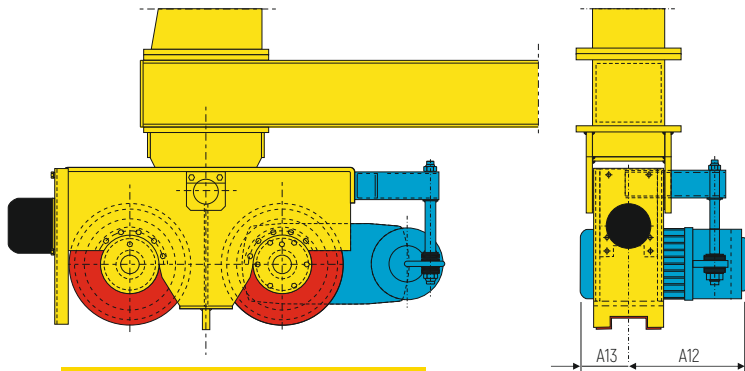

Bogie Ø 315 - 400

Carril cabeza plana:
Carril cabeza abombada:
Carril cuadrado:

$$k = L - 2r$$

$$k = L - 4 / 3r$$

$$k = L$$

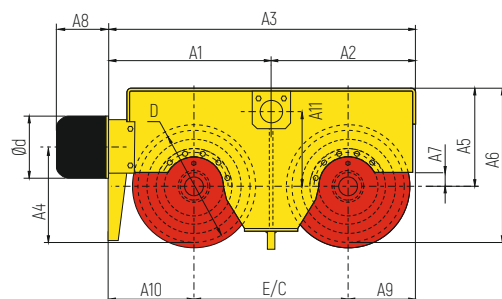
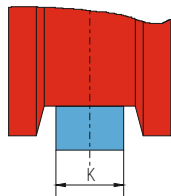
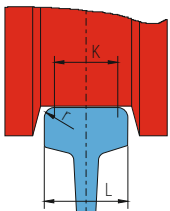

Bogie Ø 500 - 630

Bogie Ø	E/C	D	A1	A2	A3	A4	A5	A6	A7	A8	A9	A10	A11	A12	A13	Ød
315	500	315	458	457	915	315	266	423,5	42,5	131	207	208	184	287	210	160
400	550	400	545	537	1082	335	344	544	50	166	262	270	262	420	172	200
500	650	500	675	612	1287	385	369	619	30	208	287	350	277	428	165	250
630	800	630	848	773	1621	495	385	700	65	265	373	448	278	928	192	250

PLANO GENERAL DE GRÚA PUENTE

1. Final de carrera de husillo en elevación y seguridad.
2. Limitador de carga.
3. Botonera enchufable mediante conector.
4. Topes de carro en viga.
5. Soportes de las mangueras de alimentación carro y botonera atornillados.
6. Conexiones de armario y motores mediante conectores rápidos numerados.
7. Brazo tomacorrientes para alimentación de la grúa y caja de conexiones.
8. Final de carrera de traslación del carro.
9. Final de carrera de traslación del puente.
10. Tope de accionamiento del final de carrera del carro.
11. Brazo arrastrador para alimentación del carro.
12. Soportes de protección de mangueras.
13. Soportes sobre perfil para conducción de cable eléctrico.
14. Empalme perfil.
15. Soporte deslizante.
16. Tope final.
17. Carritos.
18. Radio (opcional).
19. Soporte fijación perfil a viga.
20. Soporte perfil.
21. Armario traslación.
- 21A. Armario del polipasto.
22. Barra soporte de escalera para acceso al armario eléctrico.
23. Carril de rodadura del carro.

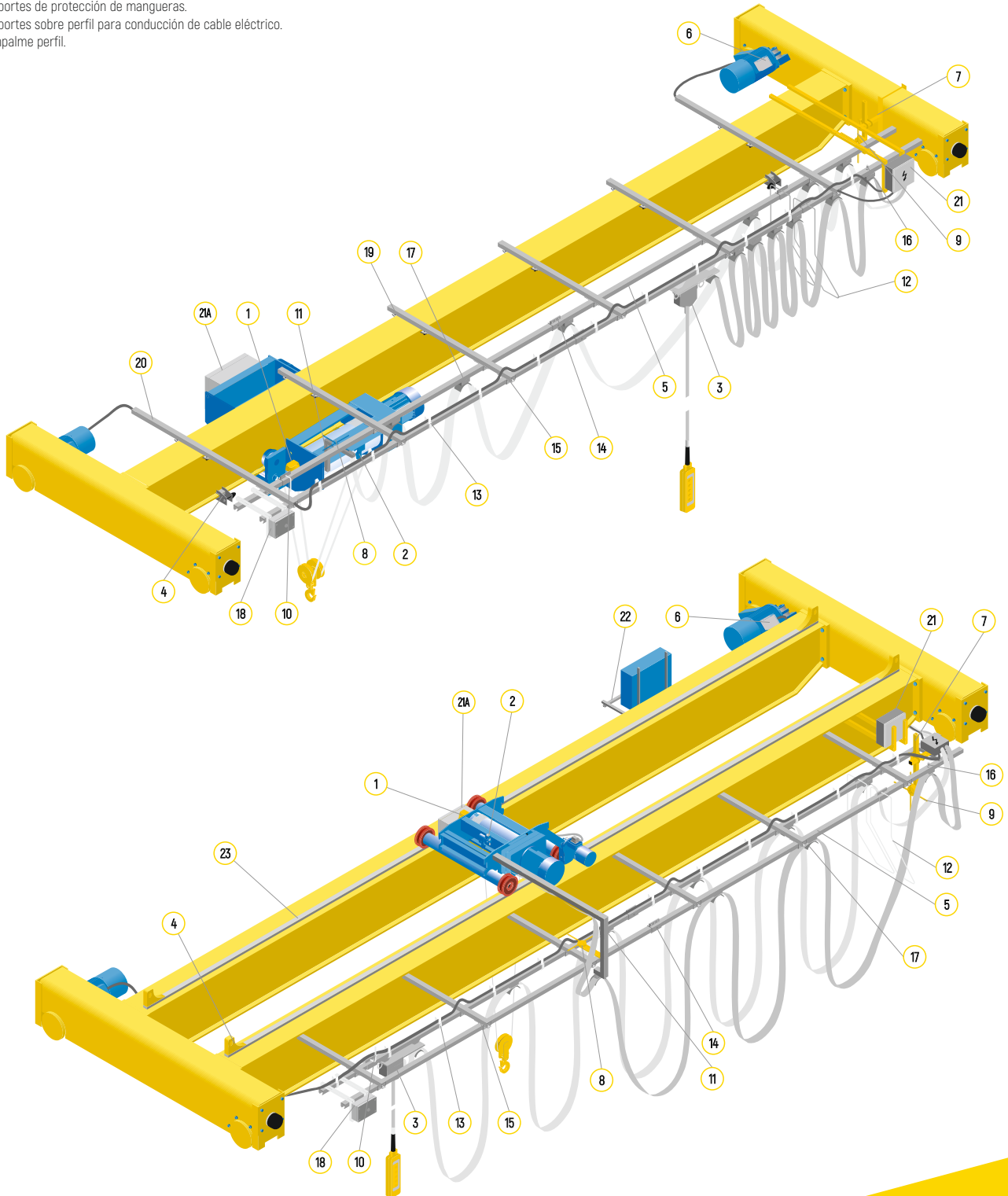

Sede Central

Apdo. 27 - B Salbatore
 20200 Beasain (Gipuzkoa) Spain
 Tel. +34 943 805 660
 Fax. +34 943 888 721
 ghcranes@ghcranes.com
 www.ghcranes.com

GH
 CRANES & COMPONENTS